

## Product Parts

- 1 - 6' Post w/Cap (x2)
- 2 - Eye Bolt (x4)
- 3 - Nut (x4)

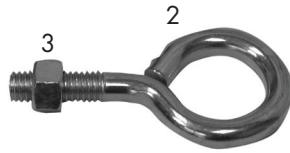

Spike Bottom



## Display Set-Up

### Step 1

Determine placement of the Posts (1) by adding at least 12" to 24" between the banner and post.

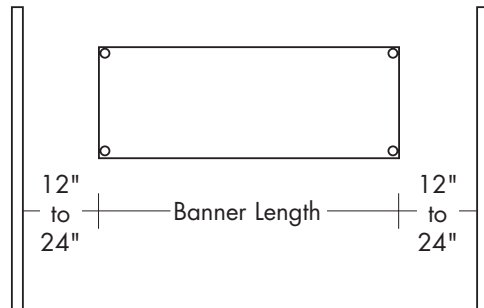

### Step 2

Position the Posts (1) so that the large surface will face each other.

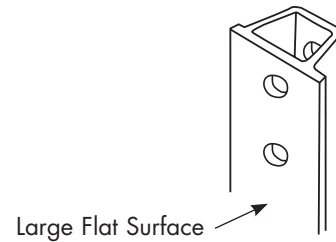

### Step 3

With a standard Post Driver (Not Included), drive the Posts (1) into the ground. Repeat for the second Post (1).



### Step 4

Determine the placement of the Eye Bolts (2) from the height of the banner. Thread two Eye Bolts (2) per Post (1) into the determined holes and finish them with a Nut (3).

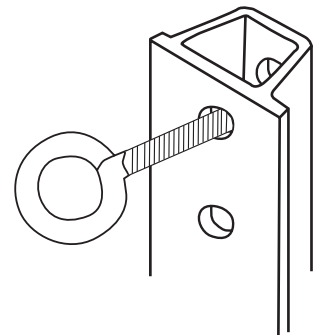

\*Do not over tighten.

### Step 5

Attach the Banner to the Eye Bolts (2) with Rope or Bungees (Not Included) and your display is complete.

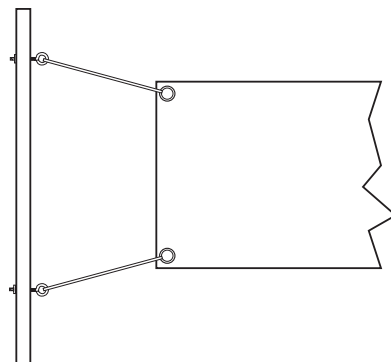

## Storage

Place all product parts into shipping box and store in a cool, dry location.

## Care

To clean, wipe with damp cloth.